

THIS DRAWING IS UNPUBLISHED. RELEASED FOR PUBLICATION, 19 .
 © COPYRIGHT 19 BY AMP INCORPORATED. ALL INTERNATIONAL RIGHTS RESERVED.

LOC	DIST	P	F	ZONE	LTR	DESCRIPTION	DATE	APPD
CH	11				B	EC 0B20-1551-98	20/NOV/98	RNP
					A	ECN 92102701		

1. WIRE RACK MARKS PERMISSIBLE IN THREAD RELIEF AFTER PLATING.

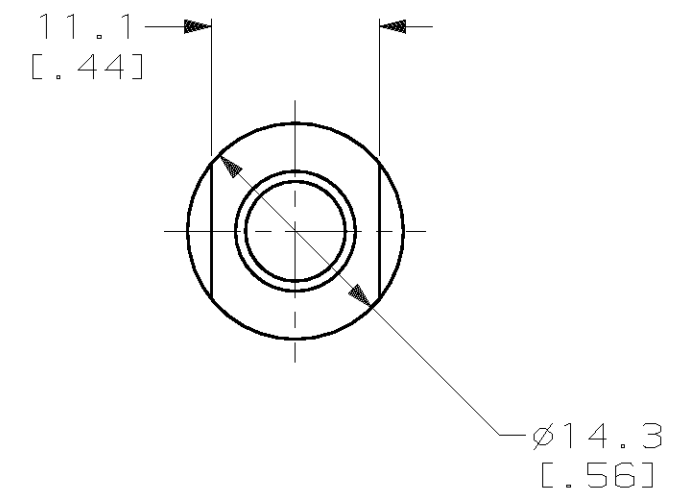
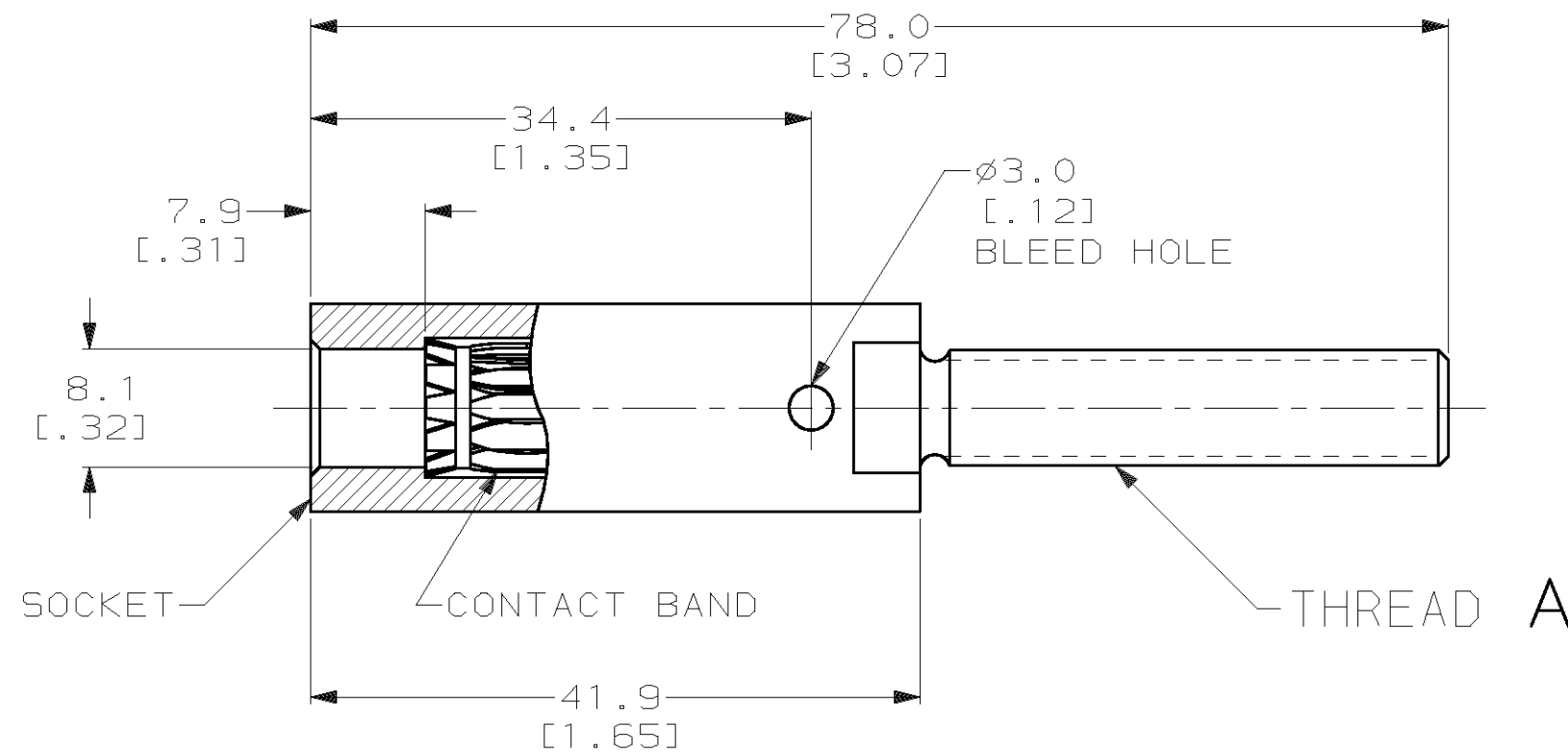

M8 X 1.25-6g	192271-3
5/16-24UNF-2A W/HARDWARE	192271-2
5/16-24UNF-2A	192271-1
THREAD A	PART NO

DO NOT SCALE PRINT. UNLESS SPECIFIED DIMENSIONS IN mm [INCHES] TOLERANCES ON: 1 PLC DEC ± 0.5 [.02] 2 PLC DEC ± 0.25 [.010] ANGLES ± -	DR D. WILSON 03-12-92	AMP Incorporated Harrisburg, PA 17105-3608						
	CHK R. JAYNE 03-13-92							
	APPD S. SIEGRIST 03-17-92							
	APPD P. GLASER 03-17-92							
MATERIAL BRASS	PRODUCT SPEC -	NAME SOCKET ASSY, 8mm						
FINISH SILVER PLATE 200-400µ THK	APPLICATION SPEC -	<table border="1"> <tr> <td>SIZE B</td> <td>CAGE CODE 00779</td> <td>DRAWING NO 192271</td> </tr> <tr> <td>SCALE 2:1</td> <td colspan="2">SHEET 1 OF 1</td> </tr> </table>	SIZE B	CAGE CODE 00779	DRAWING NO 192271	SCALE 2:1	SHEET 1 OF 1	
SIZE B	CAGE CODE 00779	DRAWING NO 192271						
SCALE 2:1	SHEET 1 OF 1							
WEIGHT -								